

VibrAlign Laser Alignment Tips

Cardan (Offset) Shaft Alignment

Cardan shafts consist of an offset drive arrangement between the driver and driven components. This means of power transmission consists of two universal joints coupled by an intermediate connecting jackshaft.

It is a misconception that cardan shafts can tolerate a large alignment error. In fact, any difference in the deflection angle between incoming and output shafts will result in a difference between the input and output angular speeds.

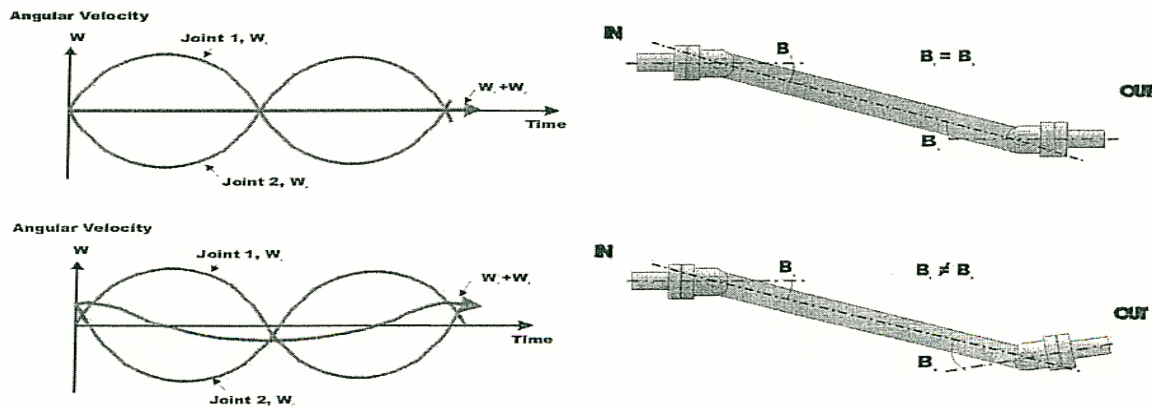

Procedure

Cardan Fixture Kit consists of a machined aluminum adjustable offset arm, rotating TD-M fixture with 4 levels, various hardware accessories such as spacer washers, center screws with locking washers, a locking lever, etc.

1. On the moveable shaft, mount the rotating TD-M fixture using either the center screws with locking washers or the included mounting bar with a threaded center hole. Mount the TD-M on the TD-M fixture.

VibrAlign

VibrAlign Laser Alignment Tips

2. On the stationary machine, mount the TD-S on the adjustable aluminum offset arm. Using the locking lever, position the offset arm such that the laser beam emitted from the the TD-S strikes the detector on the TD-M.
3. Use the thumbscrews to perform the coning (application note #) procedure to ensure that during rotation of the TD-S, the emitted beam is adjusted to scribe a circle smaller than the detector surface of the TD-M.
4. Re-adjust the aluminum offset arm, if necessary, such that the beam from the TD-S strikes the detector on the TD-M.
5. Using the thumbscrews, aim the beam emitted from the TD-M into the detector of the TD-S.

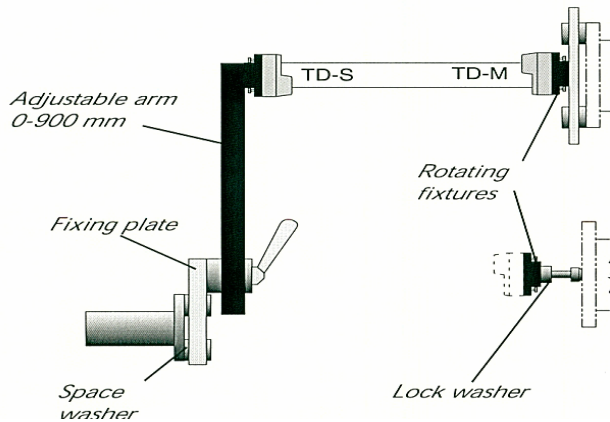

6. Using standard conventions, place the detectors at the 9:00 position and press the measurement icon at the bottom left hand of the DU's screen.
7. Rotate the detectors 180 degrees to the 3:00 position and press the measurement icon at the bottom left hand of the DU's screen. Horizontal angularity is displayed.
8. Rotate the detectors to the 12:00 position for display of the vertical angularity.
9. Proceed with the correction of angular misalignment in both the horizontal and vertical directions as would be done with the standard horizontal shaft alignment program.
10. Saving the collected data follows the procedure outlined for all shaft applications.

VibrAlign