



Troubleshooting Alignment Data

David Zdrojewski, VibrAlign, Inc.

How to compare rim and face dial indicator data to the alignment data produced by laser systems

Your company has recently purchased a laser-based alignment system. Your newly trained technicians are asked to align a critical process pump. You witness the alignment. They save the final alignment data. You review the data, but what does it mean? How does it compare to dial indicators? Why did they rotate both shafts when measuring the misalignment? Why are the numbers at the feet higher than you would like? How do you KNOW the alignment is good? The debate begins.

To make sure the alignment is good, you insist on rechecking it with dial indicators. This practical example will illustrate how to compare rim and face dial indicator data to the data produced by laser systems and help you troubleshoot the problem.

Lasers Versus Rim and Face

With most laser systems, you are encouraged to rotate both shafts during the measurement process. This is because we want to use the *rotational axis* of one shaft as the datum (reference line) and then compare the rotational axis of the second shaft to the datum. If only one shaft is rotated, the datum is dependent on the accuracy of the coupling surface. You can improve the results with indicator methods by rotating both shafts while taking alignment measurements.

The face indicator is used to measure angular misalignment. The face indicator measures the actual gap difference *at the diameter* that the face indicator travels. With larger diameters you will see larger face indicator readings. Angularity should be expressed as a slope, not a displacement. Therefore, you must divide the face reading by the diameter to calculate the true angular relationship of the two shafts.

The rim indicator is used to measure offset misalignment. When the rim indicator is set to zero and subsequently rotated 180-deg, the total indicator reading is divided by two to determine the actual offset misalignment.

Laser systems report angular misalignment as a slope and the actual offset misalignment at a user-specified axial shaft location. For close coupled machines, the user will typically

specify the coupling center as the axial location for offset misalignment because the destructive misalignment forces are generated there.

The Misalignment Example

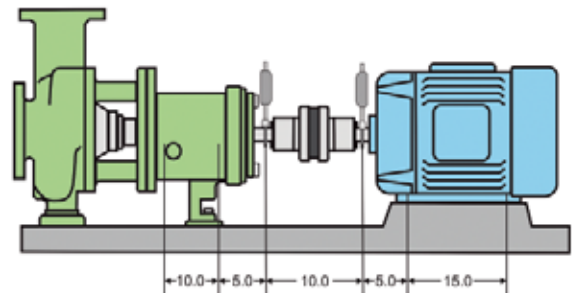

Pump Data

Pump shaft diameter at bearings: 2.55"
Radial bearing: 6313
Thrust bearing: 5313 A/C3
Radial bearing clearance (C3 Fit): .001"-.002"
Bearing Span: 9.25"

Motor Data

Frame: 444
HP: 150
Shaft Diameter: 3.375"
Drive end bearing: 6313
Opposite end bearing: NU318
Radial bearing clearance (C3 Fit): .001"-.002"

In this example, we have intentionally misaligned a motor. From a perfect alignment, the rear feet of the motor are shimmed .030-in (30-mils). There is no horizontal misalignment. Misalignment will be expressed in mils: 0.001-in = 1.0-mils. The machine dimensions have been altered slightly to simplify the example.

Graphical Result (see graph on next page)

Angular Misalignment

The slope relationship of the motor shaft to that of the pump shaft: 30-mils in 15-in.

$$30\text{-mils}/15\text{-in} = 2\text{-mils}/1\text{-in}$$

Offset Misalignment

The motor shaft is low 20-mils at axial plane of the coupling center. The motor shaft is low 16-mils at the axial plane where the rim indicator is measuring.

Graphical Result

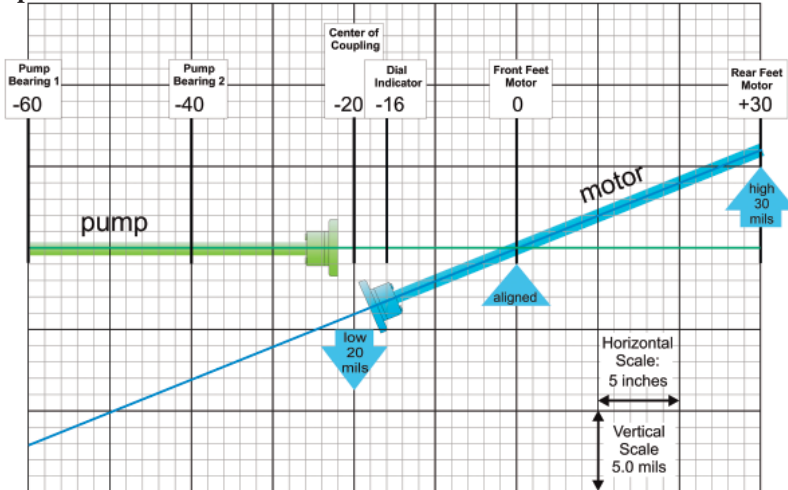

The Laser Result

Angular Misalignment

The vertical slope relationship of the motor shaft to the pump shaft: 2-mils/1-in. The coupling icon indicates that the coupling gap is larger at the bottom. The red color guidance indicates this condition is not satisfactory. Horizontally, we are reading zero.



Offset Misalignment

Vertically, the motor shaft is low 20-mils at axial plane of the coupling center. The data indicates the actual shaft misalignment not the total indicator value. Again, red means an unsatisfactory value. Horizontally, the offset misalignment is zero.

The Rim and Face Indicator Result

Angular Misalignment

We know the slope relationship = 2-mils/1-in sloping upward away from the coupling and that the face indicator is at a 6-in diameter. Therefore, if the face indicator is set to zero at 12:00 and rotated to 6:00, the dial will read +12.

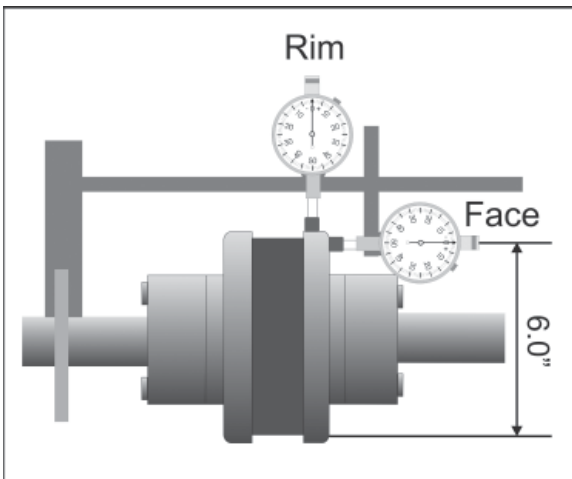

Offset Misalignment

Vertically, the motor shaft is low 16-mils at axial plane of the rim indicator. If the dial is set to zero at 12:00 and read at 6:00, the value will be +32.



the fine art of intricate duplication.

There is no pump part so complicated that ProCast can't replicate it, quickly and inexpensively. Our laser measuring technology and digital patterning process make an exacting mold of the original—and our foundry and machining services do the rest. What emerges is a piece of pure hand-crafted precision, ready to bolt in and go to work. Visit procastparts.com or call 1-800-543-6263.

ProCast



ITT

Engineered for life

circle 173 on card or go to psfreeinfo.com



Ending the Debate

In summary, the laser reports the angular misalignment as the slope relationship of the two shafts in mils/1-in. The face indicator measures coupling gap difference.

Face Reading / Diameter = Angular Misalignment

The laser reports the absolute shaft offset at the coupling center while the rim dial indicator reads twice the offset.

Rim Reading / 2 = Offset Misalignment

Other Differences to Consider

- The rim indicator values will be slightly different because the laser is calculating the offset at the center of the coupling, while the indicator is measuring at the coupling hub. If the angular misalignment is not zero, measuring in different axial planes will cause small differences on final results.
- The laser has no deflection due to gravitational forces. Consequently, you may see some differences in vertical values if you do not determine the amount of dial indicator bar sag.
- You might note that the values at the feet are larger than those at the coupling. This is simply because even small angular misalignment will result in larger and larger values

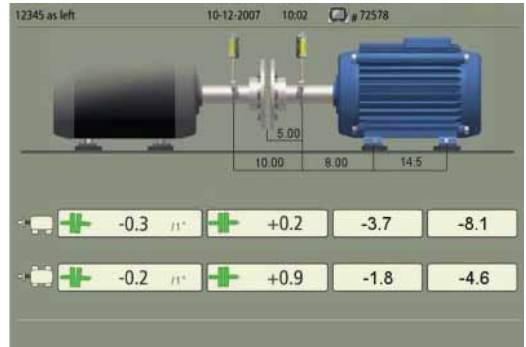

as you get further from the coupling.

- In the final example, the motor shaft is sloping downward away from the coupling. The shaft offset at the center of the coupling is 0.0. The distance from the center of the coupling to the front feet is 10.0-in. The front feet result is: $(-.3 \times 10) + 0 = -3.0$. The distance from the center of the coupling to the rear feet is 25-in. The rear feet result is: $(-.3 \times 25) + 0 = -7.5$.

P&S

David Zdrojewski is CEO of VibrAlign, Inc., 530G Southlake Blvd., Richmond, VA 23236, 800-394-3279, Fax: 804-379-0189, www.vibralign.com.

UL LISTED IND. CONT. EQ. 8077

LOAD CONTROLS INCORPORATED MODEL PMP-ES

PROTECT PUMPS

Dry Running • Cavitation • Bearing Failure • Overload

MONITOR PUMP POWER

- Best Sensitivity
- Digital Display

TWO ADJUSTABLE SET POINTS

- Relay Outputs
- Adjustable Delay Timers

4-20 MILLIAMPS ANALOG OUTPUT

COMPACT EASY MOUNTING

Only 3.25" x 6.25" x 2"

- Starter Door
- Panel
- Raceway
- Wall

UNIQUE RANGE FINDER SENSOR

- Works on Wide-range of Motors
- Simplifies Installation

LOAD CONTROLS INCORPORATED
WWW.LOADCONTROLS.COM

CALL NOW FOR YOUR FREE 30-DAY TRIAL 888-600-3247

circle 120 on card or go to psfreeinfo.com